

SmartMount® Articulating Wall Arm

For 22" to 40" (55-101 cm) LCD Screens



FLAT PANEL MOUNTS

1. Arm extends up to 20.1" (513 mm) from wall
2. One-touch tilt allows adjustment of +15/-5° without the use of tools
3. Up to ±90° of side-to-side swivel
4. ±5° of roll to level screen horizontally
5. Built-in cable management keeps cables and cords out of the way
6. Screen is centered on wall plate
7. VESA® 75, 100, 200 x 100 and 200 x 200 mm compliant
8. Non-VESA® adapter plates also available

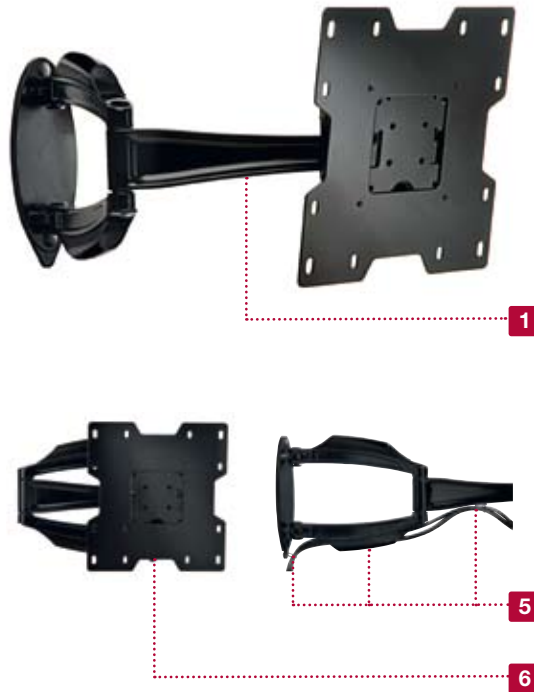

MODELS

Universal Models:

Includes standard hardware (hex or Phillips) for attaching screen to mount

SA740P	High gloss black
SA740P-S	High gloss silver

SCREEN ADAPTER



VESA® pattern

Universal Models:	75, 100, 200 x 100 and 200 x 200 mm
-------------------	-------------------------------------

SPECIFICATIONS



Distance from wall

3.3"-20.18" (83-513 mm)



Tilt | Swivel | Roll

+15/-5° | ±90° | ±5°



Max load

80 lb (36 kg)

Product Dimensions (W x H x D)

8.75"-12.75" x 8.75" x 3.3"-20.1" (222-324 x 222 x 83-513 mm)

Mounting Surfaces

Wood stud, concrete, cinder block and metal stud (Metal stud accessory required)

Ship Weight

8.45 lb (3.8 kg)

CERTIFICATIONS



ACCESSORIES



ACC919:

Security Fasteners pg# 128

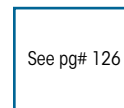

See pg# 126

WSP700:

Metal Stud Wall Plate pg# 126

For expanded product information and technical data visit www.peerlessmounts.com

TECHNICAL DRAWINGS

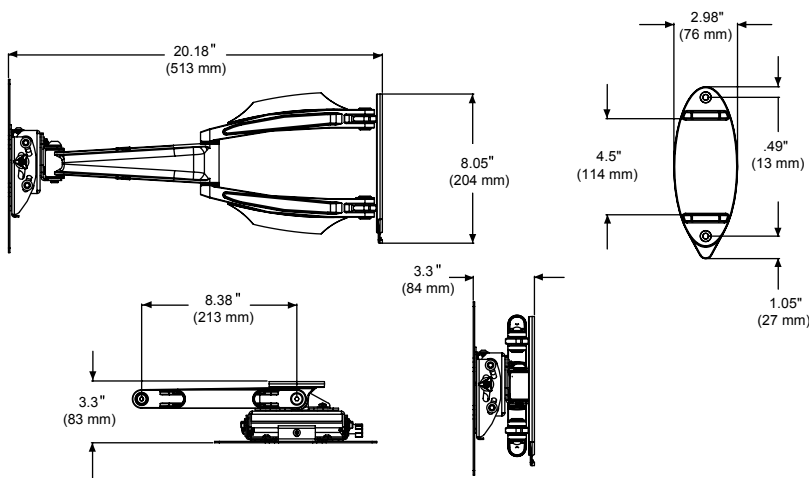

To verify mount compatibility with any LCD, plasma or projector model use MountFinder™ at www.peerlessmounts.com

CLICK: www.peerlessmounts.com

CALL: 800.865.2112

FAX: 708.865.2941