

Dual Roller Motorized FlexShade®

Fabric & Hardware Planning Sheet

SUBMITTAL
TECHNICAL INFO

Please check all appropriate selections and attach room schedule with verified dimensions.

This document is to be used with the [Motorized FlexShade Submittal](#).

On the diagram below, please provide the following information:

If Specifying a Coupled FlexShade, also indicate desired locations for couplers.

	Rear Roller Fabric: _____ Color / Number: _____ Openness Factor: _____
	*Please see Draper's Shade Fabric Reference Guide for fabric colors and specifications.
	Front Roller Fabric: _____ Color / Number: _____ Openness Factor: _____
	*Please see Draper's Shade Fabric Reference Guide for fabric colors and specifications.

Please Note: Shade fabrics can be placed anywhere in the headbox. Fabric or screen can be no closer than $\frac{13}{16}$ " to either end of the headbox.

Select Dual Roller Hardware

All Hardware Dimensions available on page 2.

Dual Endcaps Only

Dual Endcaps with Fascia

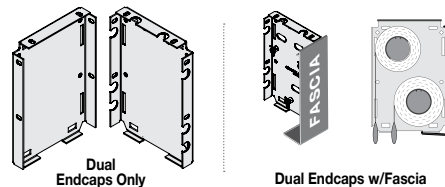

Dual Headbox

Pocket Headbox (Standard or Large; Sizes chosen by Draper)

Dual Pocket Headbox Tile Flange: Front (standard) Back Left Right None

Dual Pocket Headbox Ventilation Holes: Yes No (standard)

Pre-Drilled Shade Endcap Mounting Holes: Yes (standard) No

Pre-Drilled Pocket Headbox Mounting Holes: Yes No (standard)

Custom Headbox

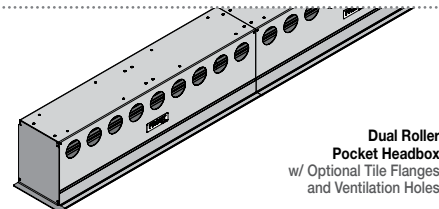

"L", "U" or "H" Channels for Light Gap Reduction

'L' Channel

'U' Channel

'H' Channel

Channel Liners

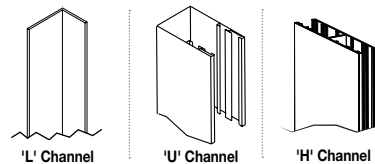

Select Hardware Finish

Does not apply to Dual Roller Pocket Headbox

Clear Anodized (standard)

Black

Ivory

White

Bronze

Custom (Contact Draper)



Draper, Inc. | 411 S. Pearl St. Spiceland, IN 47385
draperinc.com | 765.987.7999 | 800.238.7999

© 2017 All Rights Reserved | FORM: DualRoller_FSMO_Sub17

PROJECT: _____

ARCHITECT: _____

CONTRACTOR: _____

SUPPLIER: _____

DATE: _____ REVISED: _____

Dual Roller Endcap & Fascia Specifications

Endcaps: 1028 steel stamping. Complete with adapter roller bracket. Installs to wall or ceiling. Accepts fascia.

Fascia: L-shaped cover of extruded aluminum, .060 wall. Assembly snaps onto endcaps without exposed fasteners.

Clear Anodized (standard), black, white, ivory, or bronze powder coat finish available.

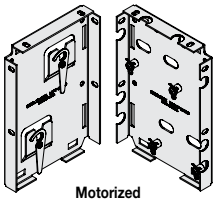

Motorized Dual Roller Endcaps

Operator	Dim A
110-220V Standard / 485 / RTS	1 3/4"
110-220V Quiet	1 15/16"

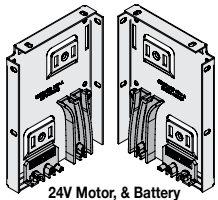
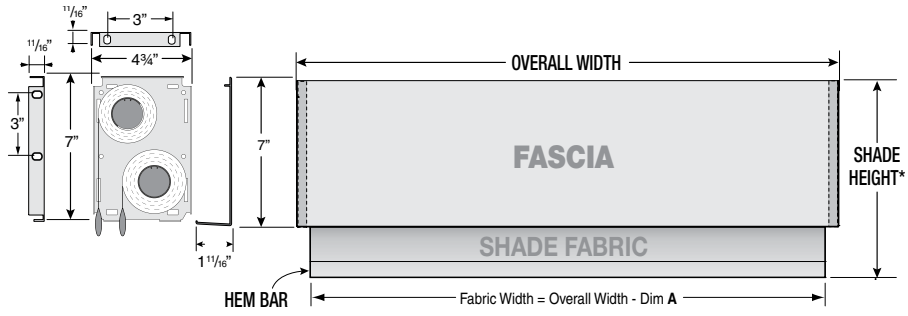

24V Motor, & Battery Dual Roller Endcaps

Operator	Dim A
Battery / 24V	1 11/16"

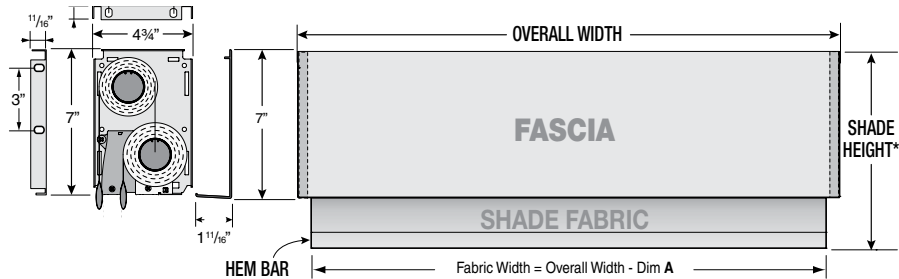

*When measuring shade height, remember to include Endcaps & Fascia.

Dual Roller Pocket Headbox Specifications

Two rollers within a single pocket style headbox. Headbox of 18 GA Steel. With or without aluminum ceiling tile lip.

Removable aluminum bottom closure attaches without exposed fasteners. Available in custom lengths for installation ahead of shades and screen. Patented by Draper. Patent information available at <http://www.draperinc.com/legal/patents/> - Downloadable 3-part specifications are available at www.draperinc.com.

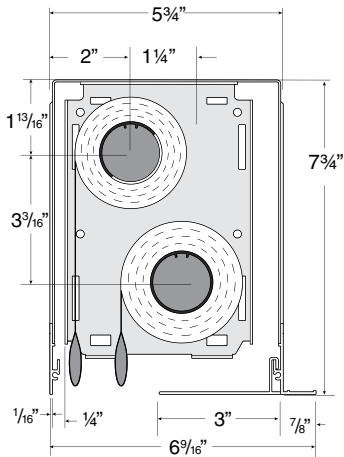

Standard Dual Roller Pocket Headbox Dimensions

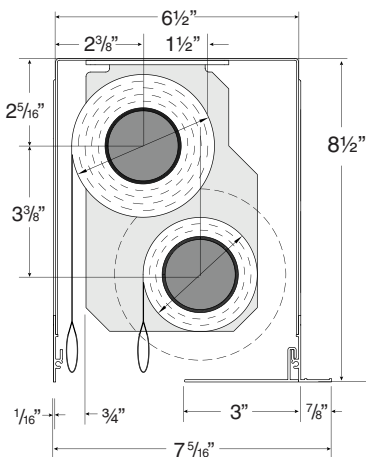
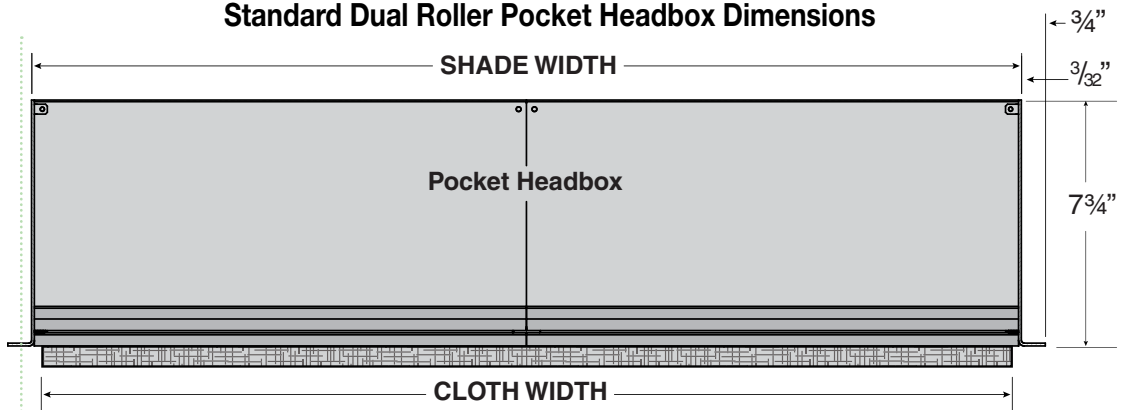

Large Dual Roller Pocket Headbox Dimensions

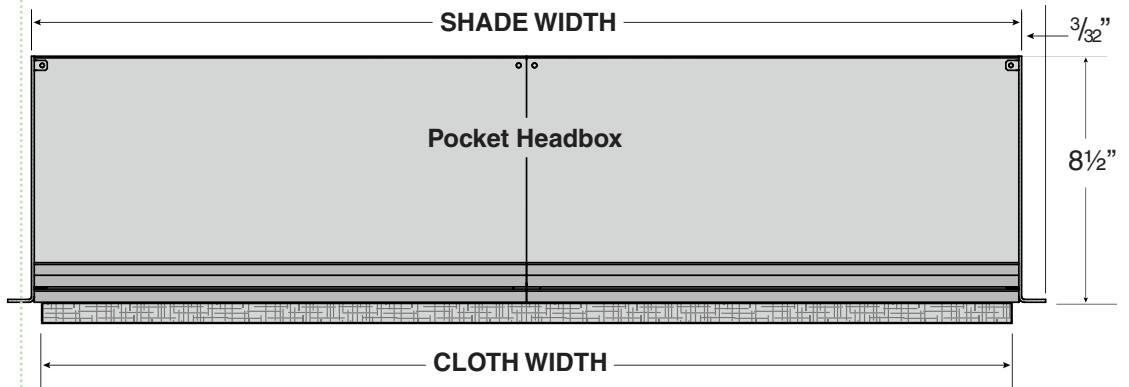

Shade Width and Rough Opening will vary depending on motor selection.