



TECHNICAL DATA SHEET - INTERNAL JOIST MOUNT ACC-120

The **ACC120 Internal Joist Mount** attaches between two ceiling joists above a finished ceiling. Its expandable design allows for attachment to joists on 16" or 20" centers. The mount features a 1 1/2-11.5 NPS threaded fitting which accepts most Peerless Extension Columns. Because it is adjustable, the installer can fine tune the point of attachment prior to installation. This flexibility will result in the optimum viewing position for the finished assembly.

Architects specifications:

The Internal Joist Mount shall be attached where indicated on the plans. It shall have a 1 1/2 - 11.5 NPS threaded fitting to accept a Peerless extension column. It shall be constructed of cold rolled steel and finished in black fused epoxy. Assembly and installation shall be done according to the instructions provided by the manufacturer.

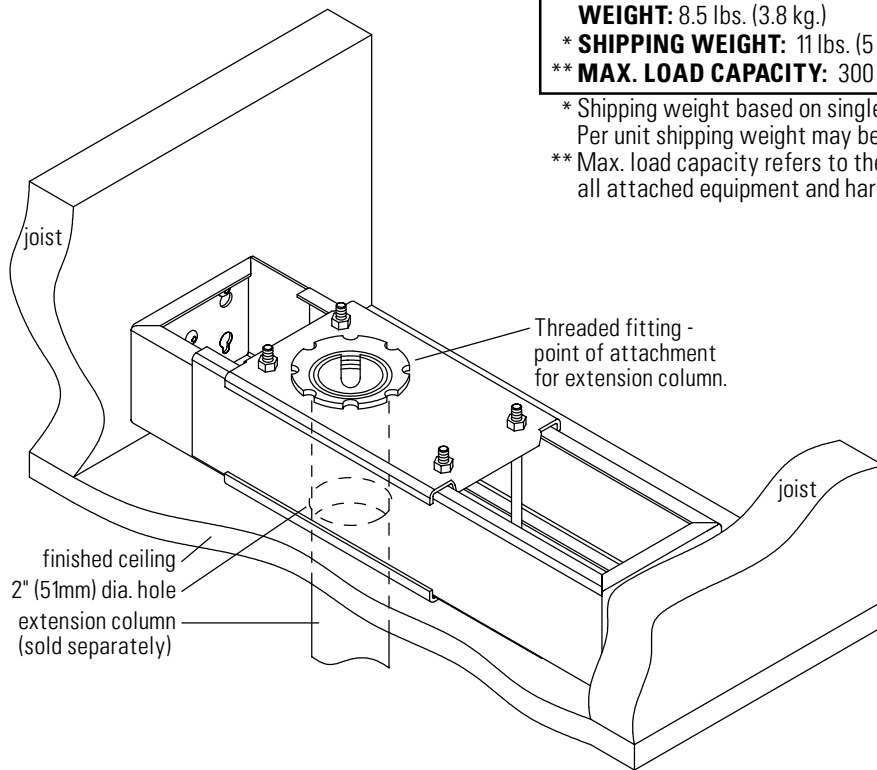

WEIGHT: 8.5 lbs. (3.8 kg.)
*** SHIPPING WEIGHT:** 11 lbs. (5 kg.)
**** MAX. LOAD CAPACITY:** 300 lbs. (136 kg.)

* Shipping weight based on single unit shipment. Per unit shipping weight may be less for bulk orders.
 ** Max. load capacity refers to the combined weight of all attached equipment and hardware.

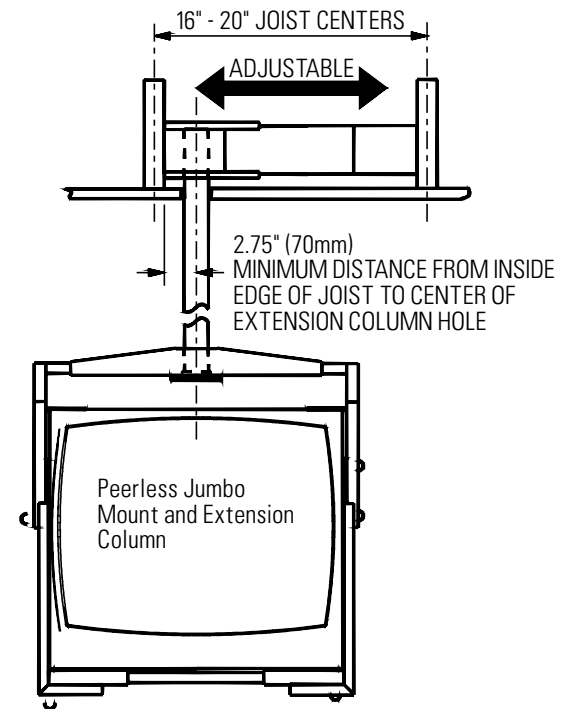

FRONT VIEW
 Peerless Jumbo Mount attached to Internal Joist Mount.

This Product must be installed by a qualified professional installer.

WARNING: IMPROPER INSTALLATION MAY RESULT IN SERIOUS PERSONAL INJURY!

When mounting Chief Manufacturing accessories, the structural system and mounting method **MUST** be capable of supporting 5 times the combined weight of the total installation.