

Flat Panel Stand

For 32" to 60" (81-152 cm) LCD and Plasma Screens



FLAT PANEL MOUNTS

1. VESA® 100, 200 x 100 and 200 x 200 mm compliant
2. Supports non-VESA® screens with additional PLP screen adapter (sold separately)
3. Fits single or back-to-back 32" to 60" (81-152 cm) flat panel screens (up to four with additional dual-screen cartridge)
4. Portrait or landscape orientation
5. Internal cable management for a clean, clutter-free appearance
6. Height adjustable on 6' (1828 mm) poles



MODELS

Dedicated Models:

Screen adapter purchased separately for non-VESA® screens*
Includes theft resistant hardware for attaching screen to mount

FPZ-600 Black

* Dedicated adapter plates come in flat black and include security fasteners

SCREEN ADAPTER



VESA® pattern

Dedicated Models: 100, 200 x 100 and 200 x 200 mm

Non-VESA® compatible screens require screen-specific adapter to be purchased separately

SPECIFICATIONS



Height Adjustment

On 6' poles (1828 mm)



Max load

200 lb (90 kg) per screen up to four screens

Product Dimensions (W x H x D)

28.57" x 72" x 36"
(730 x 1829 x 914 mm)

Mounting Surfaces

All floor surfaces



Ship Weight

Box 1: 118 lb (53.5 kg)
Box 2: 17.6 lb (7.9 kg)
Box 3: 17.6 lb (7.9 kg)

For expanded product information and technical data visit www.peerlessmounts.com

TECHNICAL DRAWINGS

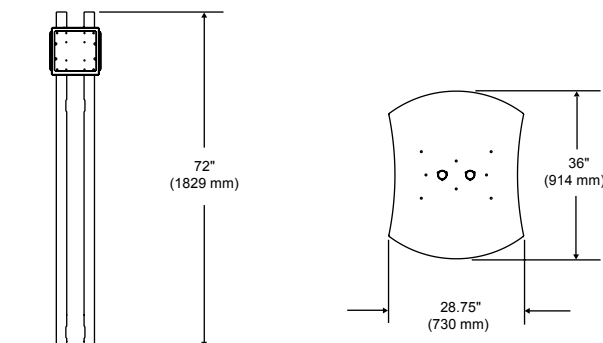

ACC604:
Dual-Screen Cartridgepg# 126

To verify mount compatibility with any LCD, plasma or projector model use MountFinder™ at www.peerlessmounts.com

CLICK: www.peerlessmounts.com

CALL: 800.865.2112

FAX: 708.865.2941