

SS7761B

All-Aluminum Speaker Stand

SPEAKER STANDS & ACCESSORIES

FEATURES AND BENEFITS

Our most versatile speaker stand is also extremely affordable! This lightweight stand features a reversible shaft design and can be used with 1 3/8" or 1 1/2" speaker cabinet inserts.

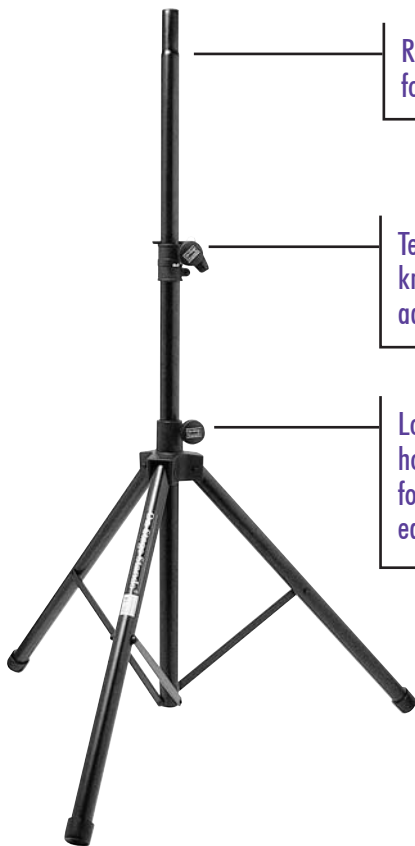

Reversible upper shaft makes for a universal fit.

Tension height adjustment knob and safety pin for added safety.

Locking/Retractable leg housing with 120° design for low center of gravity and equal weight distribution.

Ask about our speaker stand accessories ...

SSB-6500

Heavy-Duty Speaker Stand Bag

Rugged, padded nylon bag provides ample room for either 2 speaker stands, 6 mic stands or various drum hardware.

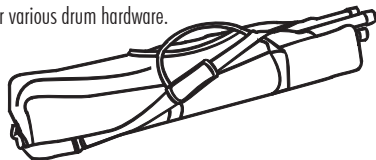

EB9760B

Exterior Mounting Bracket

Fits on 1 3/8" stand and mounts to any speaker cabinet.

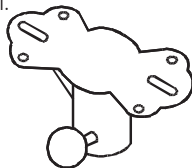

COLOR Packaging!



Our award-winning packaging is eye-catching and supplies all of the product features!

PRODUCT SPECIFICATIONS

- > **Applications:** Mid-size speakers
- > **Height Adjustment:** 44"-80"
- > **Weight Capacity:** 120 lbs.
- > **Upper Shaft Tubing:** 1 3/8" or 1 1/2"
- > **Base Spread:** 32"-48"
- > **Construction:** Aluminum
- > **Color:** Black Powder Coat Finish

Model#: **SS7761B**

Inv#: **74006**

List Price: **\$92.99**

FOCUSSED TECHNOLOGY

Call Focused Technology Today!

1-888-686-0551

www.focusedtechnology.com

On-Stage Stands®

